

Adjusting Finger Joint Bit

Adjusting Bit Height

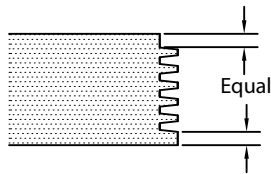

Use extra spacers in place of cutters

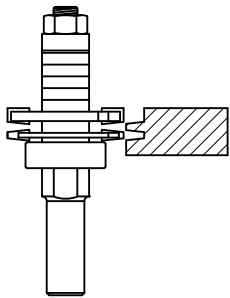

One Cutter
Stock Thickness $\frac{7}{16}$ " to $\frac{5}{8}$ "

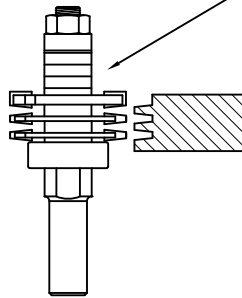

Two Cutters
Stock Thickness $\frac{5}{8}$ " to $\frac{13}{16}$ "

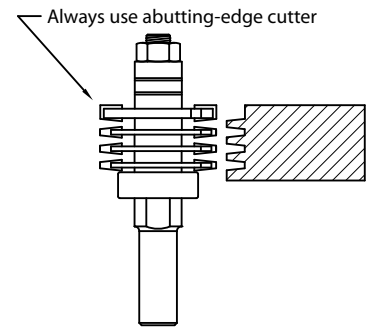

Three Cutters
Stock Thickness $\frac{13}{16}$ " to 1"

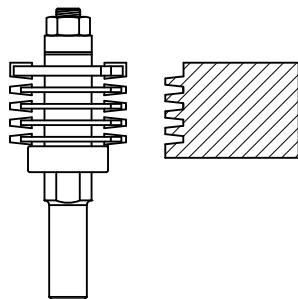

Four Cutters
Stock Thickness 1" to $1\text{-}\frac{3}{16}$ "

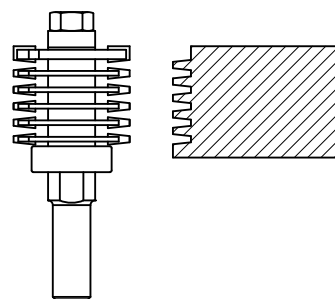

Five Cutters
Stock Thickness $1\text{-}\frac{3}{16}$ " to $1\text{-}\frac{3}{8}$ "